

K2 STONE NATURAL VENEER



INSTALLATION GUIDE



866.722.2420

K2STONE.ca

K2 STONE NATURAL VENEER

INSTALLATION GUIDE

INTRODUCTION



WHAT IS K2 NATURAL THINSTONE VENEER?

Natural K2 Stone veneer is real stone, cut 1 inch thick, making it light enough to be installed as a veneer. Sometimes referred to as thin veneer, thin stone offers all the engineered benefits that have made artificial stone so popular, while retaining the beauty and durability of the real stone. It can be used both as an interior and exterior finish.

Some popular applications include: Exterior/Interior stone walls, chimneys, pillars, gate posts, fireplaces, and barbeques.

| PRODUCT | DESCRIPTION | PALLET DIMENSION | APPROX. PACKAGE WEIGHT | APPROX. COVERAGE | UNIT |
|---|---|------------------|------------------------|-------------------|-------|
| OP* LedgeStone Veneer Flats (Natural, Ocean Mist, Black Pearl) | Cut back - 3/4" - 1 1/4" thick sizes vary *Rule of 9's flat edge grain - 10-13 lbs/sqft | 40" x 4' x 17" | 1300 lbs | 100 sqft / pallet | Sq Ft |
| OP* Fieldstone Veneer Flats (Arbutus, Tofino Sky, Carmanah Cobbles) | Cut back - 3/4" - 1 1/4" thick min 6" diameter flat face grain - 10-13 lbs/sqft | 40" x 4' x 17" | 1300 lbs | 100 sqft / pallet | Sq Ft |
| Thin Cobble Veneer | 3/4" - 1 1/4" thick, split back 4" x 8", 6" x 8", 8" x 8" sizes - tumbled | 40" x 4' x 17" | 1300 lbs | 100 sqft / pallet | Sq Ft |
| Pacific Ashlar Veneer | Cut top and bottom 3/4" - 1 1/4" thick 2", 4", 6", 8" heights - random lengths | 40" x 4' x 17" | 1300 lbs | 100 sqft / pallet | Sq Ft |
| Autumn Gold, Camas Creek, Echo Valley, Elk Ridge & Sun River Veneer Flats | Cut back - 3/4" - 1 1/4" thick min 3" x 6" flat edge or face grain 10-13 lbs/sqft | 40" x 4' x 17" | 1300 lbs | 100 sqft / pallet | Sq Ft |
| Autumn Flame Veneer Flats | Cut back - 3/4" - 1 1/4" thick min 1" x 6" face - 10-13 lbs / sqft | 40" x 4' x 17" | 1300 lbs | 100 sqft / pallet | Sq Ft |
| Thin Stone Veneer Corner | Min 2" height w/ 4" outside return Thin Stone specs | 40" x 4' x 17" | 800 lbs | 50 lnft / pallet | Ln Ft |

K2 STONE NATURAL VENEER

INSTALLATION GUIDE

THINSTONE INSTALLATION REQUIREMENTS

- All exterior surfaces are required to have a water resistant barrier installed. (See local building codes.)
- Applications that use an expanded metal lath must use a lath that is corrosion resistant.
- When using expanded metal lath in your application, a 1/2 inch thick scratch coat must be applied. Be sure to attach the metal lath with the small cups pointing upwards.
- It is recommended to allow a scratch coat at least 24 hours to dry.
- Safety Glasses and a dust mask should always be worn when cutting or trimming any of K2 Stone's products.
- Type 'S' mortar is utilized for all Natural Thinstone installations.
- The use of an acrylic bonding agent mixed in with the mortar is recommended to add strength to the installation.
- It is recommended that 100% of the back of each stone be covered by a minimum 1/2 inch coat of mortar.
- If corner pieces are required for the application, the corner pieces should be installed prior to any flats. Start by installing some corner pieces; next fill in with flats leaving sufficient lead time to allow corners to set. Repeat process until completion.
- It is suggested that 48 hours after application, the stonework be watered down and a cleaning agent applied to remove any dirt.
- All of K2 Stone's products are washed prior to packaging. We recommend washing the product before installation to remove any of the debris that may have accumulated during transportation.

**Consult with local building codes prior to any installation. Local building codes must be adhered to at all times.*



K2 STONE NATURAL VENEER INSTALLATION GUIDE

SURFACE PREPERATIONS FOR NATURAL K2 STONE VENEER

EXTERIOR FRAMED WALL

Installation applies both to wood and steel stud framed walls. All material size and spacing needs to be in compliance with local building codes and/or any manufacturer's structural requirements. An exterior sheathing material is required to provide a base for the application surface. Cover sheathing with a weather resistant vapor barrier. Overlap vapor barrier at the joints by a minimum of 4 inches. Consult local building codes prior to installation to determine if a rainscreen is required. Install 2.5 lb galvanized expanded metal lath with galvanized nails or screws, be sure to attach the metal lath with the small cups pointing upwards. Fasteners should be installed at a minimum of 6 inches on center vertically and 16 inches horizontally. It is important to note that in a corner application, the expanded metal lath needs to wrap the corner completely and overlap the expanded metal lath to a minimum of 4 inches. Apply 1/2 inch thick scratch coat, allow 24 hours to dry, and your Natural K2 Stone Veneer can now be applied. See Figure #1.

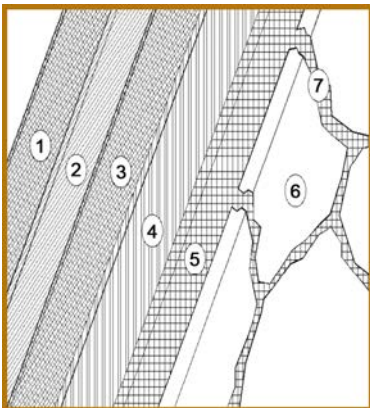

Figure #1

- (1) Sheathing
- (2) Building paper or vapor barrier
- (3) Rain screen *As Per Local Building Codes
- (4) Galvanized metal lath
- (5) Mortar
- (6) Natural K2 thinstone veneer
- (7) Mortar



**Consult with local building codes prior to any installation. Local building codes must be adhered to at all times.*

INTERIOR FRAMED WALL

** Note - A wall board is required to provide a base for the application surface.*

Install a vapor barrier and 2.5lb galvanized expanded metal lath over wall board with recommended galvanized nails or screws, be sure to attach the metal lath with the small cups pointing upwards. Expanded metal lath over concrete board is not necessary unless local building codes require it. Concrete board that is properly installed (rough side out) can have Natural K2 Stone Veneer applied right to it. Fasteners should be installed at a minimum of 6 inches on center vertically and 16 inches on center horizontally. It is important to note that in a corner application, the expanded metal lath needs to lap over the expanded metal lath that is applied to each adjacent wall surface by a minimum of 4 inches. Apply 1/2 inch thick scratch coat, allow 24 hours to dry, and apply the Natural K2 Stone Veneer. See Figure #1.

K2 STONE NATURAL VENEER INSTALLATION GUIDE

SURFACE PREPERATIONS FOR NATURAL LEDGESTONE VENEER

INSULATED CONCRETE FORMS

Apply vapor barrier. Next install the expanded metal lath as specified by the manufacturer of the insulated forms. Concrete fasteners that secure the 2.5 lb galvanized expanded metal lath to the wall, will need to be long enough to penetrate clear through the insulation and secure into the cured poured concrete wall. Be sure to attach the metal lath with the small cups pointing upwards. Apply a 1/2 inch thick scratch coat, allow 24 hours to dry, and then apply your Natural Thinstone Veneer. See Figure #2.

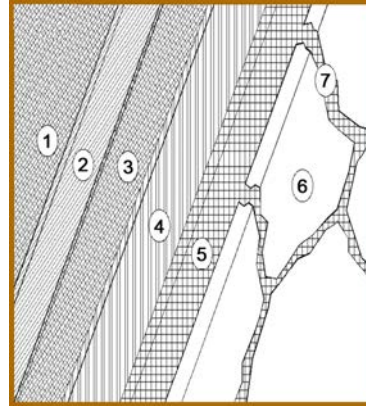

Figure #2

- (1) Concrete
- (2) Insulation
- (3) Building paper or vapor barrier
- (4) Galvanized metal lath
- (5) Mortar
- (6) Natural K2 thinstone veneer
- (7) Mortar

NEW CONCRETE MASONRY WALL

** Note - Including new concrete block and/or newly poured concrete walls.*

No special preparation is required for a concrete block wall. When working with a poured concrete wall, it is important to take extra time to examine the entire surface as it may have areas of form release agents on the concrete surface. To remove this oil, contact an industry professional for recommended cleaning solutions and/or score the area with a wire brush. After these surfaces are cleaned, rinsed and allowed to dry, the Natural Thinstone Veneer can be installed directly to the concrete wall. See Figure #3.

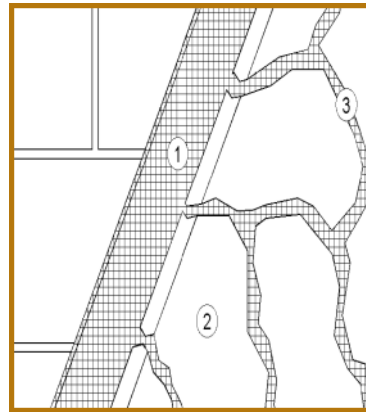

Figure #3

- (1) Mortar applied directly to untreated masonry or concrete
- (2) Natural K2 stone veneer
- (3) Mortar joint

EXISTING CONCRETE MASONRY WALL

** Note - Including sealed and/or painted concrete and brick.*

It is important to verify with a builder or engineer that an existing wall is strong and sound. Sandblast the surface to remove any paint or sealer if required. Rinse thoroughly. Once the surface has dried, Natural K2 Stone Veneer can be applied directly to the clean surface. If this application is not reasonable, another option is to apply expanded metal lath to the painted or sealed surface with corrosion resistant concrete screws or nails. Then apply a 1/2 inch scratch coat and allow 24 hours to dry.

**Consult with local building codes prior to any installation. Local building codes must be adhered to at all times.*

K2 STONE NATURAL VENEER INSTALLATION GUIDE

MORTAR APPLICATION AND THINSTONE INSTALLATION

1. Properly prep the surface as previously described.
2. Mix Type 'S' Mortar (As Per Manufacturer's Instructions) to a creamy consistency. The use of an acrylic bonding agent mixed (as per the manufacturer's directions) with a bag of type 'S' cement is recommended to add bond strength to the installation.
3. Ensure surfaces are clean of dirt, sand, or loose particles.
4. Trowel a mortar scratch coat on the wall approximately 1/2 inch thick over the metal lath. Allow 24 hours to dry.
5. Slightly dampen the scratch coat before installing K2 Stone veneer. A spray bottle could be used to dampen mortar.
6. Apply mortar to cover the entire back of each stone. Each stone should be covered by a minimum 1/2 inch of mortar.
7. Press stone into scratch coat, rotating slightly, forcing some of the mortar to squeeze out freely. Any mortar forced out beyond the finished joint can be troweled to finish joint.
8. Use a grout bag or trowel to fill all the joints. As the mortar stiffens, tool to the desired depth and brush off all excess.

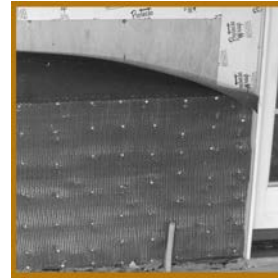

Application of galvanized lath to exterior wall.



Application of scratch coat to surface of exterior wall.



Application of mortar onto Natural Thinstone Veneer.



Application of Natural Thinstone Veneer.

CLEANING AFTER INSTALLATION

Excess mortar and film may be removed using a certified cleaning solution (contact an industry professional for recommendations). Always choose a non-conspicuous area to test cleaning solution prior to application. Rinse thoroughly with clean water.

SEALING (Optional)

Stone may be sealed with a quality breathable sealer only after the mortar has cured, which takes 3 to 4 weeks on interior applications. Follow manufacturer's directions on the application of sealer. Sealers must be periodically reapplied, especially on exterior applications, and could alter the natural coloring of the stone. Always choose a non-conspicuous area to test sealer prior to application.

K2 STONE NATURAL VENEER INSTALLATION GUIDE

MAINTENANCE

RECOMMENDED CLEANING PROCEDURES

The first step is to determine your stone type (If unsure contact your local dealer)

Recommended Cleaning Procedures for Ocean Pearl Products

1. Use a pressure washer or spray nozzle to rinse any debris off of the stone.
2. If stone is still not clean proceed to step 3
3. In a container mix a non-acid based cleaning product with water.
4. Scrub stone with a brush and the soapy solution.
5. Use a pressure washer or spray nozzle to rinse any debris off of the stone.
6. If stone is still not clean proceed to step 7
7. In a container dilute muriatic acid as per manufacturer's directions - typically 20 parts water to 1 part muriatic acid. **Make sure to Wear Safety Equipment As Directed By Cleaning Product Manufacturer*
8. Scrub stone with a brush and the acid wash solution.
9. Use a spray nozzle to rinse any remaining acid off of the stone.

**Wear Eye Protection During Cleaning Procedures*

**Make sure to Wear Safety Equipment As Directed By Cleaning Product Manufacturer*

Recommended Cleaning Procedures for Big Sky Products

1. Use a pressure washer or spray nozzle to rinse any debris off of the stone.
2. If stone is still not clean proceed to step 3
3. In a container mix a non-acid based cleaning product with water.
4. Scrub stone with a brush and the soapy solution.
5. Use a pressure washer or spray nozzle to rinse any debris off of the stone.
6. If stone is still not clean repeat steps 4 and 5

**Wear Eye Protection During Cleaning Procedures*

**Make sure to Wear Safety Equipment As Directed By Cleaning Product Manufacturer*

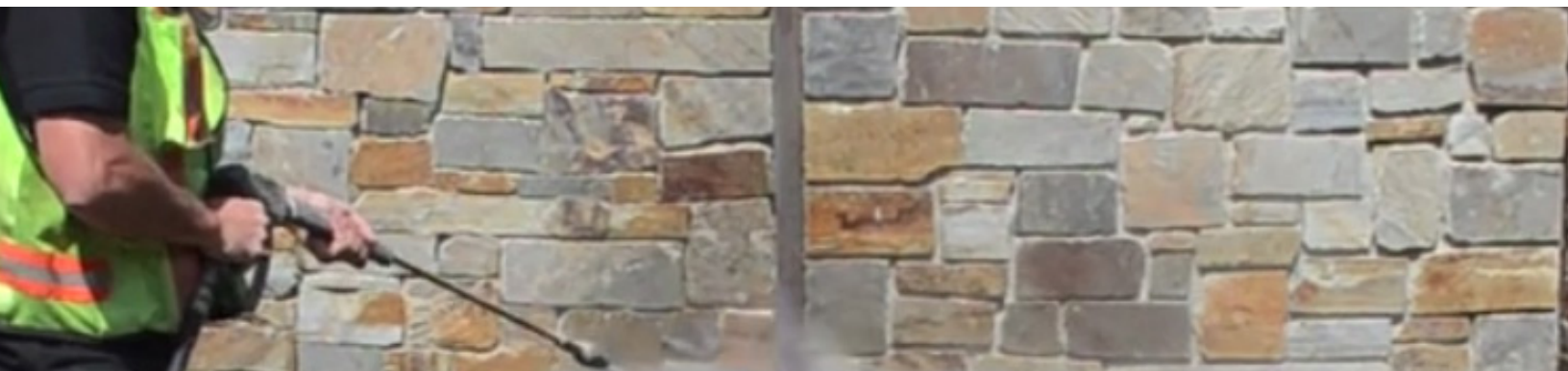

K2 STONE NATURAL VENEER



INSTALLATION GUIDE



REAL NATURAL STONE

